

"E" Model TRANE wiring diagram

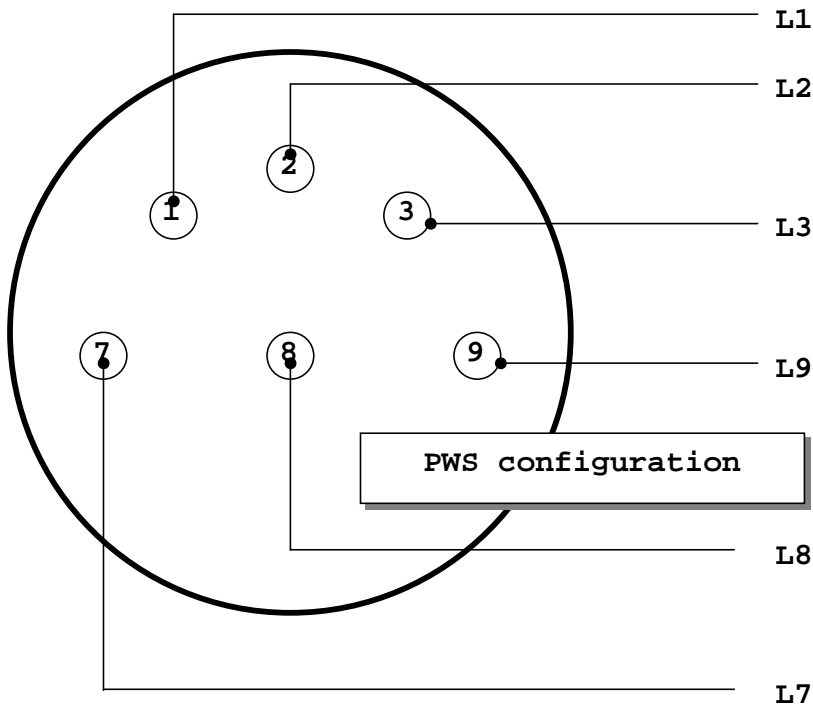

Model CRHE
Small Diameter Motor

Nom HP	Voltage	FULL LOAD AMPS	
		Water Cooled	Air Cooled
75 6 cyl	200-60-3	210	256
	230-60-3	182	222
	460-60-3	90	112
100 8 cyl	200-60-3	282	344
	230-60-3	244	299
	460-60-3	118	148

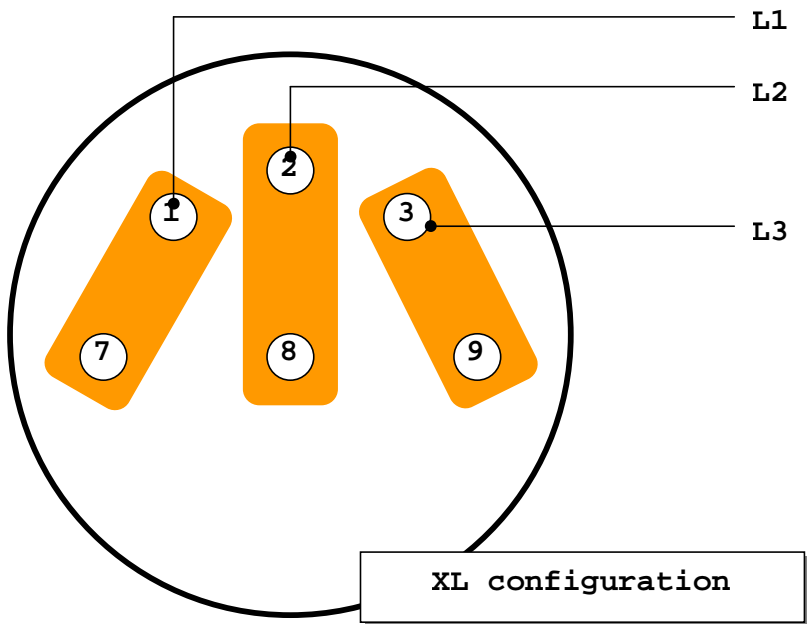

Model "E"
Large Diameter Motor
"6 lead" motor

Nom HP	Voltage	FULL LOAD AMPS	
		Water Cooled	Air Cooled
50 4 cyl	200-60-3	161	187
	230-60-3	133	155
	460-60-3	67	78
60 5 cyl	200-60-3	207	231
	230-60-3	170	191
	460-60-3	85	96
75 6 cyl	200-60-3	246	290
	230-60-3	202	248
	460-60-3	101	124
100 8 cyl	200-60-3	324	378
	230-60-3	266	310
	460-60-3	133	155

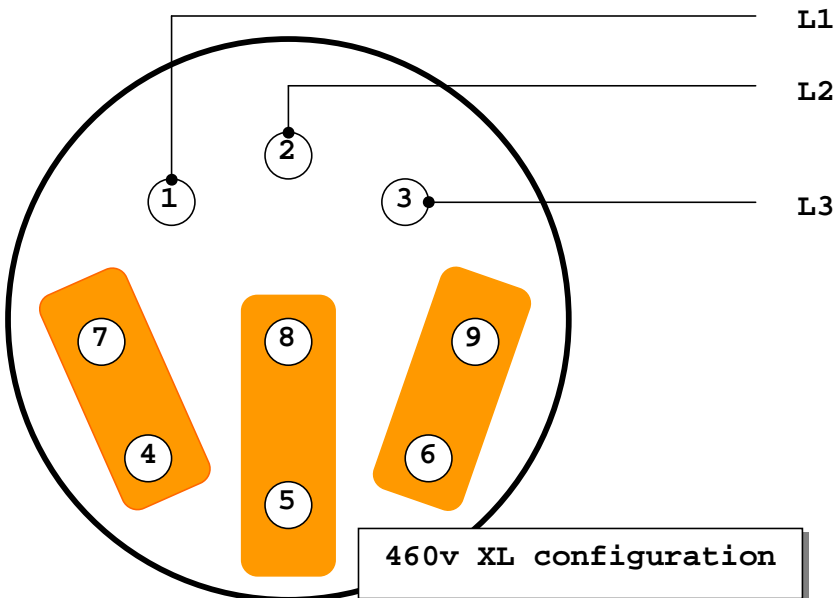
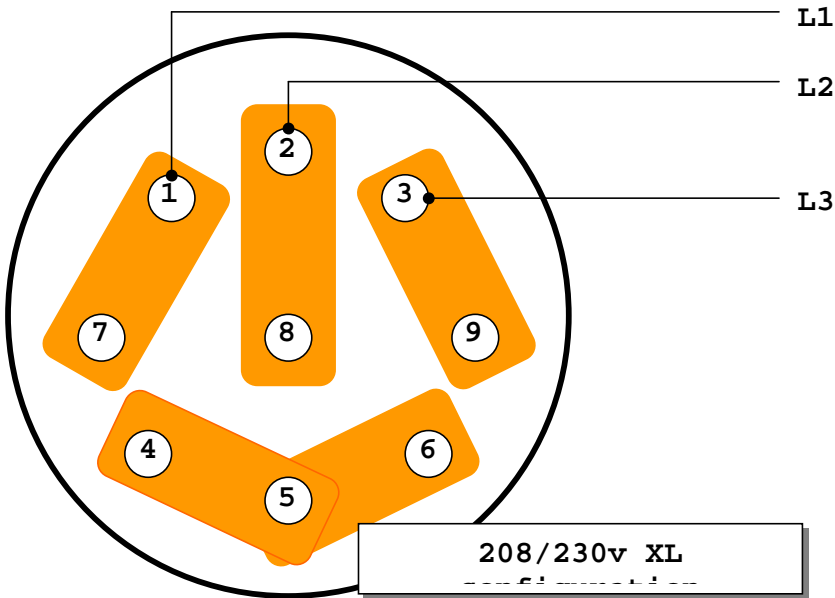
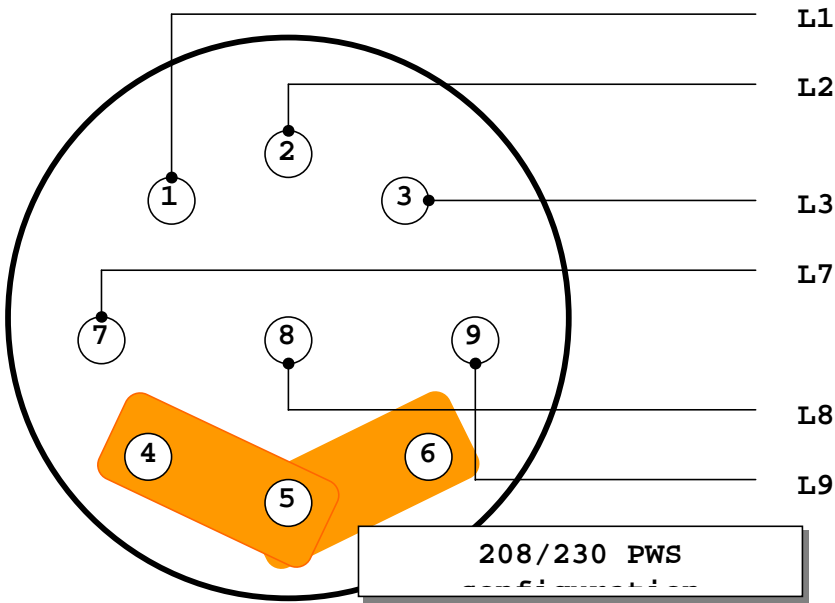

Model "E"
Large Diameter Motor
"9 lead" motor

Nom HP	Voltage	FULL LOAD AMPS	
		Water Cooled	Air Cooled
50 4 cyl	200-60-3	147	171
	230-60-3	133	155
	460-60-3	67	78
60 5 cyl	200-60-3	188	211
	230-60-3	170	191
	460-60-3	85	96
75 6 cyl	200-60-3	224	264
	230-60-3	202	248
	460-60-3	101	124
100 8 cyl	200-60-3	294	342
	230-60-3	266	310
	460-60-3	133	155

W A R N I N G

The "9 lead" motor cannot be wired for 460v PWS. You must use the "6 lead" motor for the 460v