

"F" Model TRANE wiring diagram

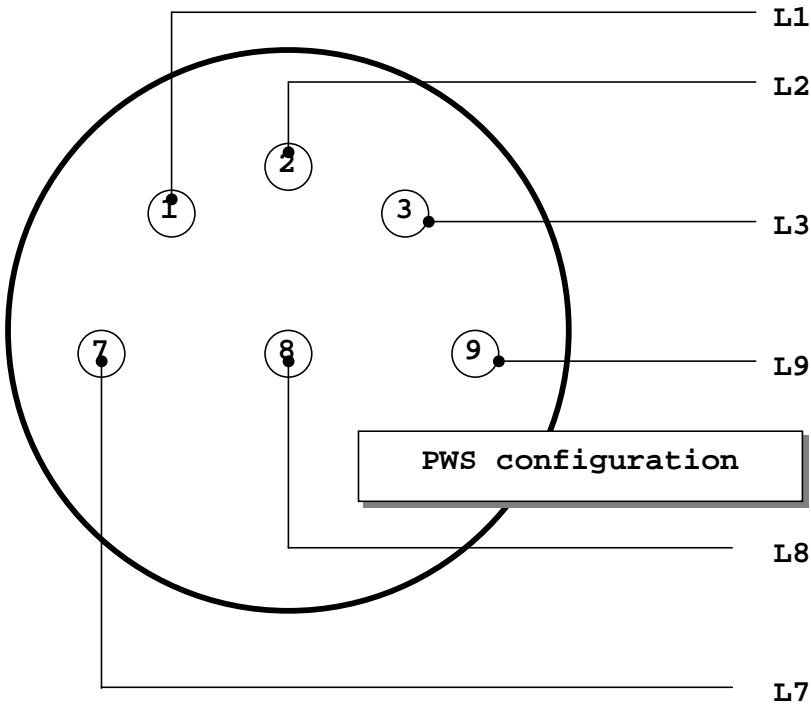

Model "F" "6 lead" motor			
Nom HP	Voltage	FULL LOAD AMPS	
		Water Cooled	Air Cooled
20 4 cyl	200-60-3	-	86
	230-60-3	58	65
	460-60-3	29	33
25 5 cyl	200-60-3	-	109
	230-60-3	72	80
	460-60-3	36	40
30 6 cyl	200-60-3	-	129
	230-60-3	87	96
	460-60-3	44	48
40 8 cyl	200-60-3	-	178
	230-60-3	114	130
	460-60-3	57	65

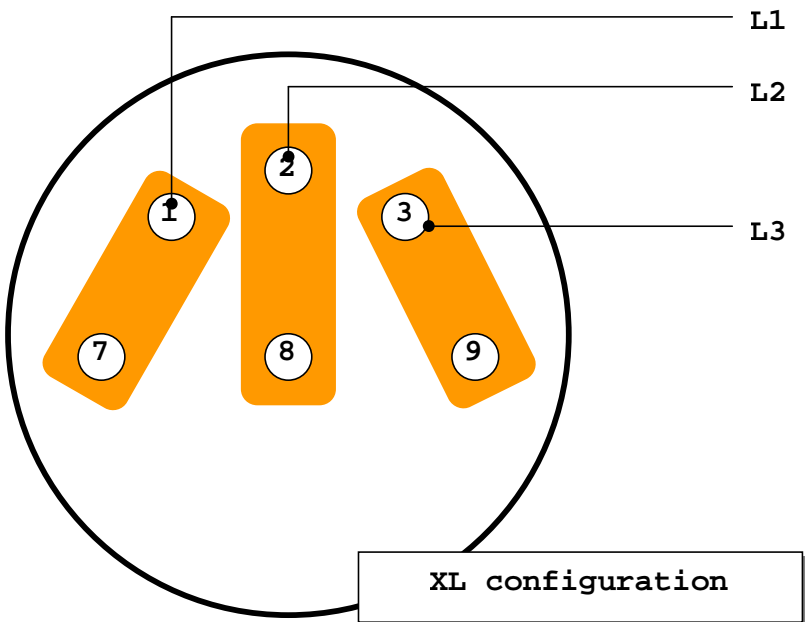

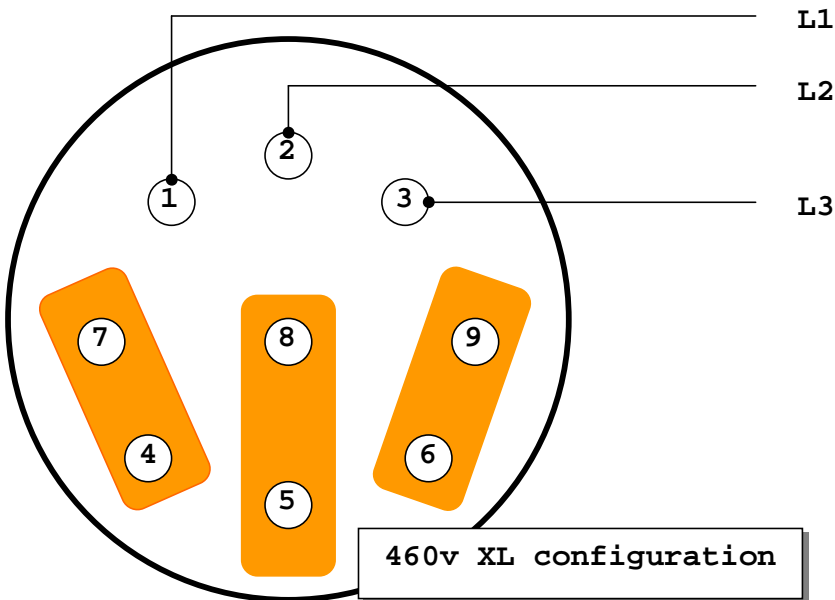
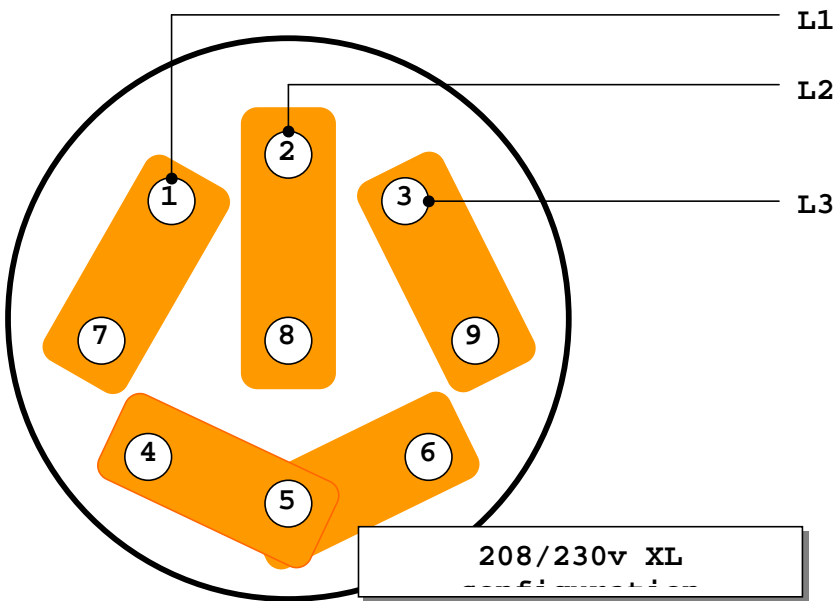
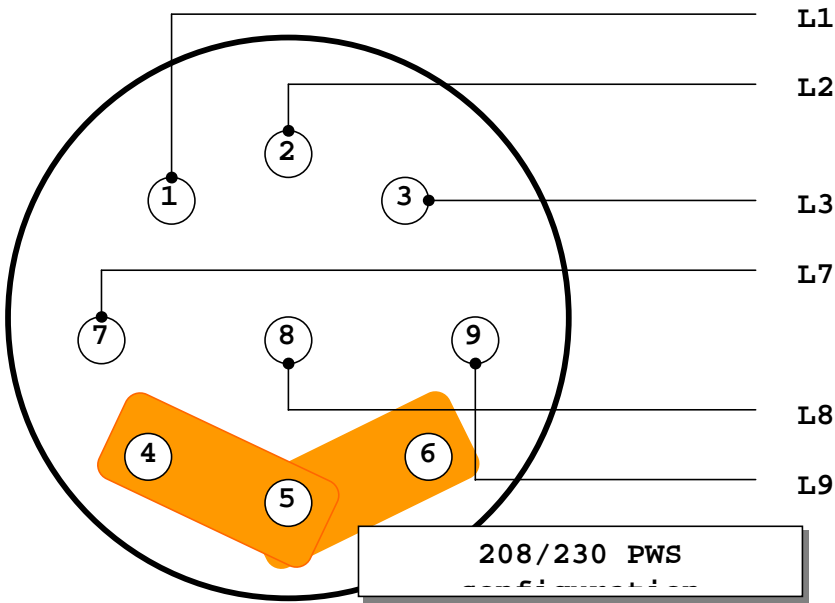

Model "F"
"9 lead" motor

Nom HP	Voltage	FULL LOAD AMPS	
		Water Cooled	Air Cooled
20 4 cyl	200-60-3	64	72
	230-60-3	58	65
	460-60-3	29	33
25 5 cyl	200-60-3	80	88
	230-60-3	72	80
	460-60-3	36	40
30 6 cyl	200-60-3	97	106
	230-60-3	87	96
	460-60-3	44	48
40 8 cyl	200-60-3	126	144
	230-60-3	114	130
	460-60-3	57	65

W A R N I N G

The "9 lead" motor cannot be wired for 460v PWS. You must use the "6 lead" motor for the 460v