

Differential pressure controls Type MP 54, 55 and 55A

Contents

	Page
Introduction	3
Features	3
Approvals	3
Materials in contact with the medium	3
Technical data	4
Ordering	4
Design	5
Terminology	5
Funktion	5-6
Dimensions and weight	7

Introduction

MP 54 and MP 55 oil differential pressure controls are used as safety switches to protect refrigeration compressors against low lubricating oil pressure.

If the oil pressure fails the oil differential pressure control stops the compressor after a certain time period.

MP 54 and 55 are used in refrigerating systems using fluorinated refrigerants.

MP 55A is used in refrigerating systems with R717 (NH₃). MP 55A can also be used in systems with fluorinated refrigerant.

MP 54 has a fixed differential pressure setting. It also incorporates a thermal time relay with a fixed release time setting.

MP 55 and 55A have adjustable differential pressure and are available both with and without thermal time relay.

Features

- Wide regulating range
- Can be used for deep freeze, refrigeration and air conditioning plant
- Can be used for all normal fluorinated refrigerants
- Electrical connection at the front of the unit
- Suitable for both alternating and direct current
- Screwed cable entry for cables from 6 to 14 mm diameter
- Small contact differential
- Meets the requirements of EN 60947

Approvals

CE mark according to EN 60947-5

GL, Germanischer Lloyd, Germany

Versions having UL and CSA approvals can be supplied to special order.

RINA, Registro Italiano Navale, Italy

CCC, China Compulsory Certificate

Materials in contact with the medium

Unit type	Material
MP 54 MP 55	Stainless steel 19/11, no. 1.4306 to DIN 17440 Deep-drawn steel plate, no. 1.0338 to DIN 1624 Free cutting steel, no. 1.0718 to DIN 1651
MP 55A	Stainless steel 19/11, no. 1.4306 to DIN 17440 Deep-drawn steel plate, no. 1.0338 to DIN 1624 Free cutting steel, no. 1.0401 to DIN 1652

Technical data

Control voltage
230 V or 115 V a.c. or d.c.

Permissible voltage variation
+10 → -15%

Max. working pressure
PB = 17 bar

Max. test pressure
p' = 22 bar

Temperature compensation
The time relay is temperature-compensated in the range -40 to +60°C

Screwed cable entry
Pg 13.5

Cable diameter
6 → 14 mm

Max. bellows temperature
100°C

Enclosure
IP 20 to IEC 529 / EN 60529

Contact loads

Type A:
On time relay output contacts M-S:
AC15: 2 A, 250 V
DC13: 0,2 A, 250 V

Type B without time relay:
AC15: 0,1 A, 250 V
DC13: 12 W, 125 V

Type C without time relay:
AC1: 10 A, 250 V
AC3: 4 A, 250 V
DC13: 12 W, 125 V

Properties according to EN 60947:

Wire dimensions
solid/stranded 0.2 - 1.5 mm²
flexible, w/out ferrules 0.2 - 1.5 mm²
flexible, with ferrules 0.2 - 1 mm²
Tightening torque max. 1.2 NM
Rated impulse voltage 4 kV
Pollution degree 3
Short circuit protection, fuse 2 Amp
Insulation 250 V
IP 20

Ordering
For fluorinated refrigerants

Type	Differential Δp bar	Switch differential max. Δp bar	Operation range, LP side bar	Time relay release time s	Contact load (see technical data)	Code no.		
						Connection		
						1/4 in./6 mm Flare	1 m cap.tube 1/4 in. ODF solder	Cutting ring 6 mm
MP 54	Fixed 0.65	0.2	-1 → +12	0 ²⁾	B	060B029766		
	Fixed 0.65	0.2	-1 → +12	45	A	060B016666		
	Fixed 0.9	0.2	-1 → +12	60	A	060B016766		
	Fixed 0.65	0.2	-1 → +12	90	A	060B016866		
MP 55	0.3 → 4.5	0.2	-1 → +12	45	A	060B017066	060B013366	
	0.3 → 4.5	0.2	-1 → +12	60	A	060B017166		060B018866
	0.3 → 4.5	0.2	-1 → +12	60	A	060B017866¹⁾		
	0.3 → 4.5	0.2	-1 → +12	90	A	060B017266		
	0.3 → 4.5	0.2	-1 → +12	120	A	060B017366	060B013666	
	0.3 → 4.5	0.2	-1 → +12	0 ²⁾	B	060B029966		060B029566
	0.65 → 4.5	0.4	-1 → +12	0 ²⁾	C	060B029466⁴⁾		

For fluorinated refrigerants and R717 (NH₃)

Type	Differential Δp bar	Switch differential max. Δp bar	Operation range, LP side bar	Time relay release time s	Contact load (see technical data)	Code no.	
						Connection	
						Ø 6,5 / Ø 10 mm weld nipple	Cutting ring 6 mm
MP 55A	0.3 → 4.5	0.2	-1 → +12	45	A	060B017466	060B018266
	0.3 → 4.5	0.2	-1 → +12	60	A	060B017566	060B018366
	0.3 → 4.5	0.2	-1 → +12	60	A	060B017966¹⁾	
	0.3 → 4.5	0.2	-1 → +12	90	A	060B017666	060B018466
	0.3 → 4.5	0.2	-1 → +12	120	A	060B017766	060B018566
	0.3 → 4.5	0.2	-1 → +12	0 ²⁾	B	060B029866²⁾	060B029666

¹⁾ With operational light that remains on during normal operation.

Note: If the operational light goes out, the compressor should not run longer than the release time.

²⁾ Versions without time relay are for applications where an external time relay is required - perhaps with a different release time than the one specified.

³⁾ 060B0169 meets Copeland specifications. UL-approved versions can be supplied.

⁴⁾ Approved according to EN 60947-4, -5.

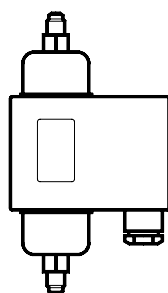

Design

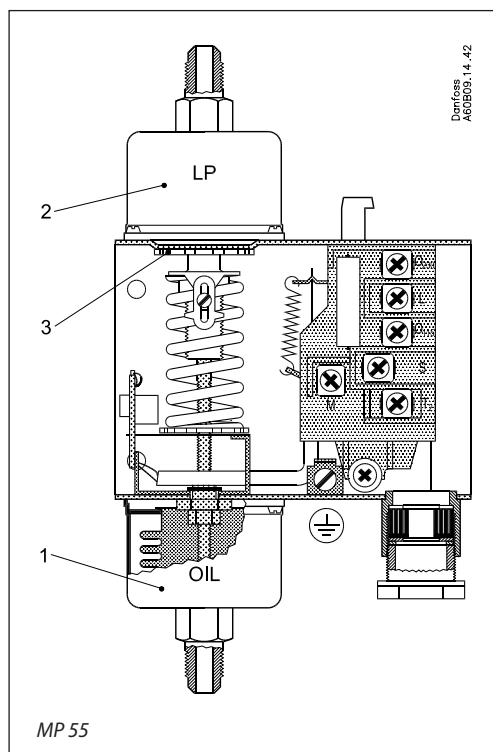

1. Connection to pressure side of lubrication system, OIL
2. Connection to suction side of refrigeration plant, LP
3. Setting disc
4. Reset button
5. Test device

The operation of the pressure control is conditional only on the differential pressure, i.e. the difference in pressure between the two counteracting bellows, whereas it is independent of the absolute pressure acting on both bellows. The MP 55 and 55A can be set for different differential pressures by the setting disc (3). The set differential pressure can be read from the internal scale. The MP 54 has a fixed differential and has no pressure setting disc. The factory-set differential pressure is stamped on the front plate of the control.

Terminology

Differential range

The pressure difference between LP and OIL connections within which the control can be set to operate.

Scale reading

The differential between the oil pump pressure and the pressure in the crankcase that exists at the moment the contact system cuts in current to the time relay on falling oil pressure.

Operating range

The pressure range on the LP connection within which the control can operate.

Contact differential

The pressure rise above the set differential pressure (scale reading) necessary to cut off current to the time relay.

Release time

The period for which the differential pressure control allows the compressor to run with too low an oil pressure during start-up and operation.

Function

If there is no oil pressure on starting, or if the oil pressure falls below the set pressure during operation, the compressor will stop after the release time has elapsed. The electrical circuit is divided into two completely separate circuits, a safety circuit and an operational circuit.

The timer (e) in the safety circuit is activated when the effective lubricating oil pressure, the *oil differential pressure* (the difference between the oil pump pressure and suction pressure), is lower than the set value. The timer is deactivated when the oil differential pressure is more than the set value plus the contact differential.

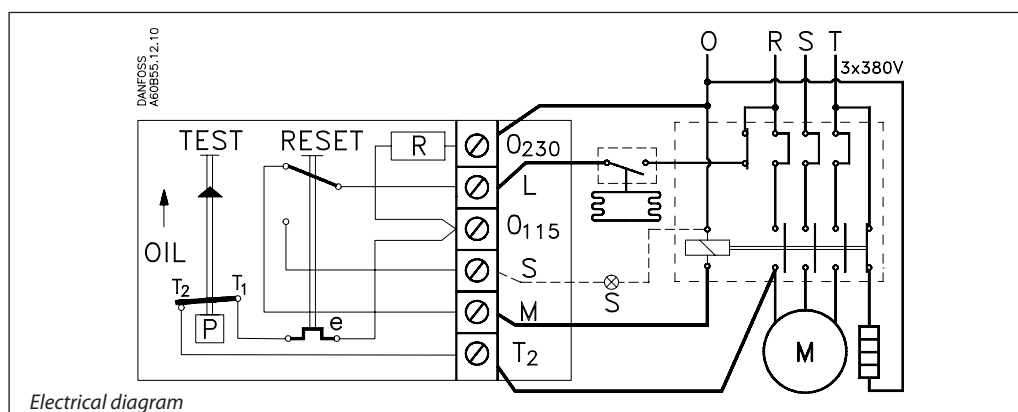

Electrical diagram

Function
(continued)

The two diagrams below explain the terms "oil differential pressure" and "contact differential", both have to be considered when using oil differential pressure controls.

The first diagram shows the function of the differential control during start; the second shows the function of the control during operation.

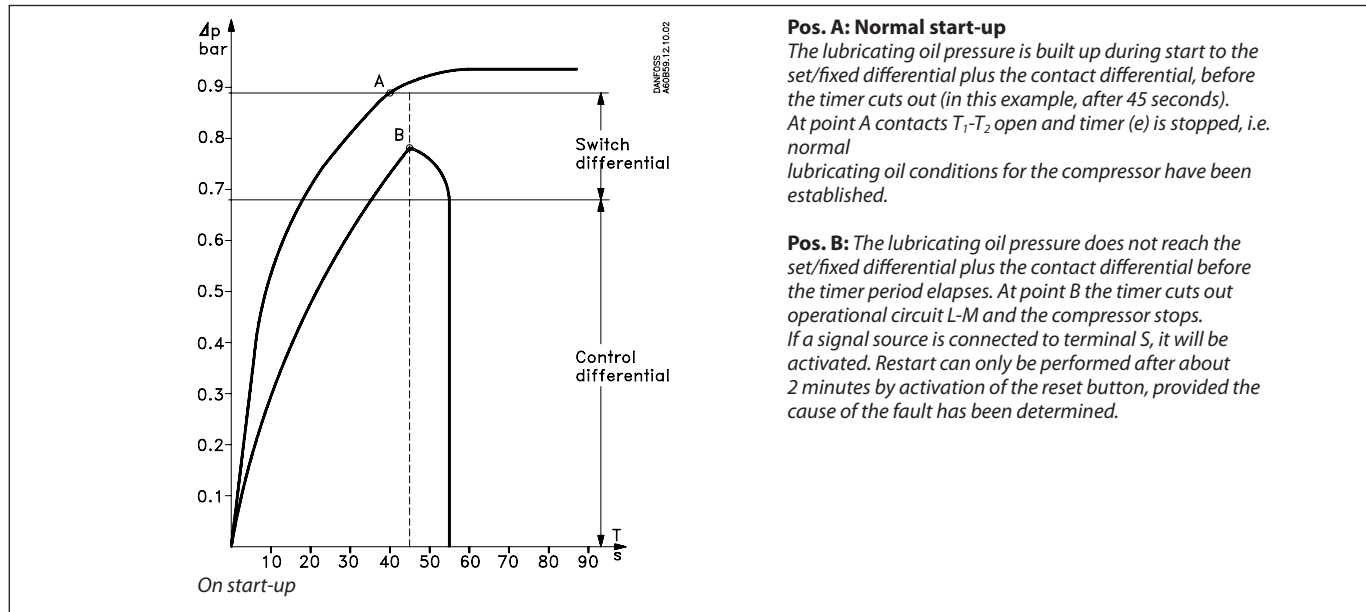

Pos. A: Normal start-up

The lubricating oil pressure is built up during start to the set/fixed differential plus the contact differential, before the timer cuts out (in this example, after 45 seconds). At point A contacts T₁-T₂ open and timer (e) is stopped, i.e. normal lubricating oil conditions for the compressor have been established.

Pos. B: The lubricating oil pressure does not reach the set/fixed differential plus the contact differential before the timer period elapses. At point B the timer cuts out operational circuit L-M and the compressor stops. If a signal source is connected to terminal S, it will be activated. Restart can only be performed after about 2 minutes by activation of the reset button, provided the cause of the fault has been determined.

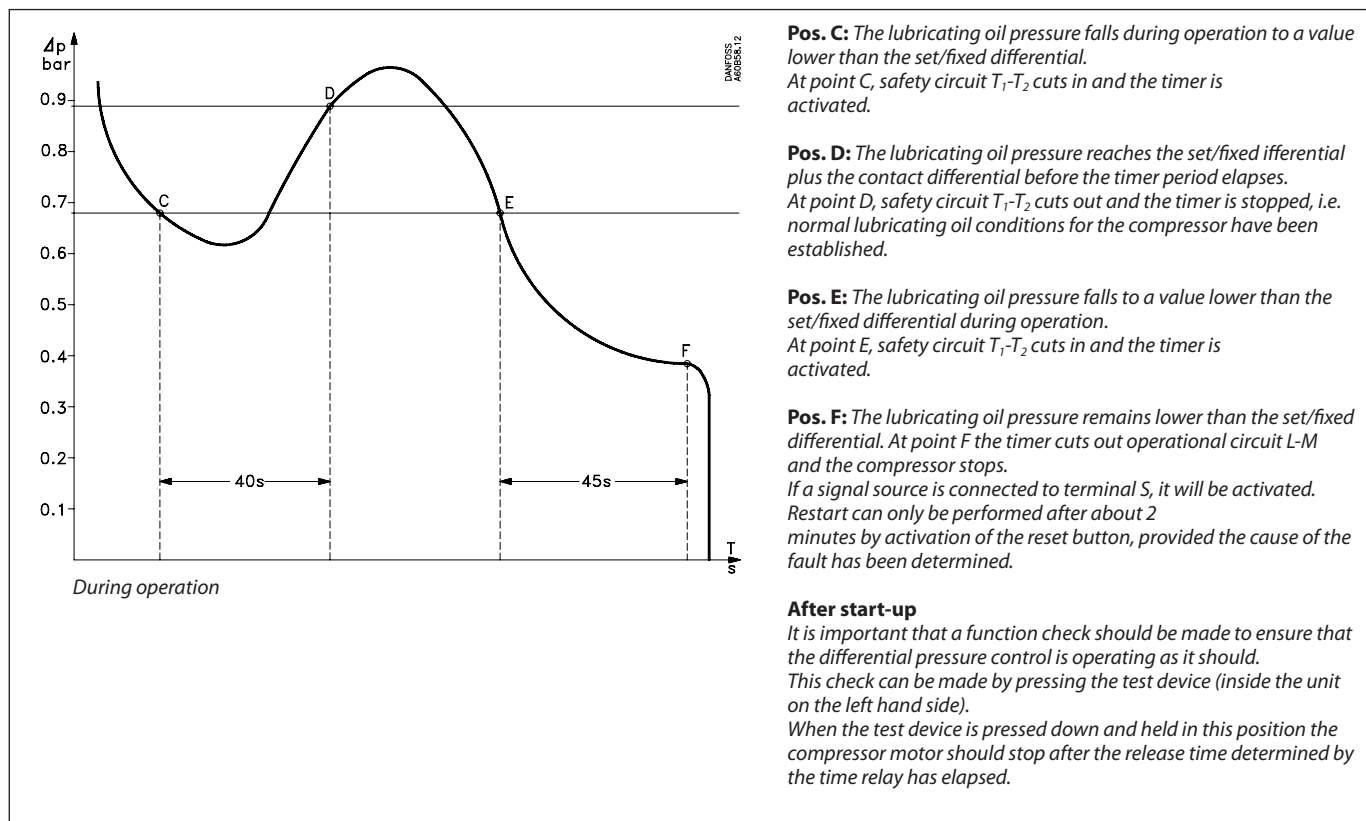

Pos. C: The lubricating oil pressure falls during operation to a value lower than the set/fixed differential. At point C, safety circuit T₁-T₂ cuts in and the timer is activated.

Pos. D: The lubricating oil pressure reaches the set/fixed differential plus the contact differential before the timer period elapses. At point D, safety circuit T₁-T₂ cuts out and the timer is stopped, i.e. normal lubricating oil conditions for the compressor have been established.

Pos. E: The lubricating oil pressure falls to a value lower than the set/fixed differential during operation. At point E, safety circuit T₁-T₂ cuts in and the timer is activated.

Pos. F: The lubricating oil pressure remains lower than the set/fixed differential. At point F the timer cuts out operational circuit L-M and the compressor stops. If a signal source is connected to terminal S, it will be activated. Restart can only be performed after about 2 minutes by activation of the reset button, provided the cause of the fault has been determined.

After start-up

It is important that a function check should be made to ensure that the differential pressure control is operating as it should. This check can be made by pressing the test device (inside the unit on the left hand side). When the test device is pressed down and held in this position the compressor motor should stop after the release time determined by the time relay has elapsed.

Dimensions and weight

